

Sec 4 and 5 Parents Engagement 2025



24 JANUARY 2025

Key Personnel

Designation	Name
Principal	Mrs Grace Chua
Year Head Upper Secondary	Mr Mohamed Ashiq
HOD Mother Tongue	Mr Wong Wei Long
HOD Maths	Mr Victor So
HOD English	Mdm Foong Woon Sin
HOD Science	Mr Richmond Ang
HOD Humanities	Mr Sim Keng Yam
HOD ICT	Mr Chua Khoon Wee

Designation	Name
HOD SD	Mr Sim Chun Siang
HOD SM	Mr Hafidz Khan
HOD Partnership	Mr Ow Kok Meng
SH CCE	Mr Daniel Ng
SH Ed Technology	Mr Koh Chun Kiat
ST Maths	Mr Chang Hock Boon
ST Social Studies	Mdm Hairunisa
EGC Counsellor	Mr Mohammad Syahril

Agenda

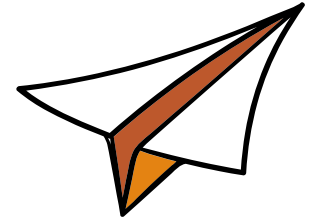

-
- Welcome Address by Principal
 - Student Wellbeing and Academic Support
 - CCA and LEAPS matters
 - Post Secondary Options
 - Q & A



Opening Address

Sec 4 / 5 Parents' Engagement Session
24 Jan 2025, via TEAMS

~ Principal, Mrs Grace Chua



VMV

- **Vision: Confident Learners, Caring & Resilient Citizens**
- **Mission: Inspiring Lives, Nurturing Talents, Realising Dreams**
- **Values: Pride, Responsibility, Integrity, Zeal, Empathy**



Strategic Directions

- **Future-Ready Education:** fostering life-long learning habits, developing critical thinking and creative problem-solving skills, preparing students to adapt to a rapidly changing world
- **Holistic Education:** focus on acquiring skills and dispositions, grow EQ and adaptability
- **Harnessing Tech Integration:** cater to individual learners and diverse learning needs and contexts. High ability learners may benefit from advanced tech but high-need learners may require deeper engagement and stronger socio-emotional support before suitable tech solutions are introduced. **Teachers' judgement must bridge what tech provides and what students need**
- **Mental wellness: Students' well-being & Agency (3Cs – Create, Connect, Contribute)**

SCHOOL VISION

Confident Learners , Caring & Resilient Citizens

SCHOOL MISSION

Inspiring Lives • Nurturing Talents • Realising Dreams

Strategic Foci:

- 1. Quality Learning through Skilful Design & Delivery**
- 2. Character Building through a Holistic Education**
- 3. Forging Synergistic Partnerships with Parents & the Community**

SCHOOL VALUES

Pride • Responsibility • Integrity • Zeal • Empathy (PRIZE)

Commendable Performance – 2024 GCE N Level

4NT

No. of As	No. of students	CCA
3	2	Tinkers Club Table Tennis

4NA

No. of Distinctions	No. of students	CCA
5	6	NCDCC, NPCC Basketball, Badminton
4	5	Tinkers Club, NPCC Table Tennis, Volleyball, Basketball

Eligibility for PFP and DPP

	2022	2023	2024
PFP	20	12	23.7
DPP	61	56	71.1

Eligibility for Promotion to 5NA

	2022	2023	2024
PRSS (%)	89.7	72.7	88.2
National (%)	78.9	77.2	76.7

Commendable Performance – 2024 GCE O Level

4E

No. of Distinctions	No. of Students	CCA
8 Distinctions	1	NCDCC
7 Distinctions	6	NCDCC, NCC, CO, Volleyball, Basketball, Badminton
6 Distinctions	12	NCC, NPCC, CO, Choir, Table Tennis, Volleyball Basketball
5 Distinctions	10	NCC, NCDCC, NCC, Choir, Volleyball, Badminton, Football

4E5N JC / Poly Eligibility		
2022	2023	2024
93.5	98.2	93.1

National Exams 2025

*GCE O-Level Examinations	Dates
Listening Comprehension	Tue, 8 Jul (PM) Wed, 8 Oct (PM)
Practical & Written Examinations	Mon, 2 Jun Tue, 23 Sep – Fri, 26 Sep Wed, 1 Oct – Tue, 14 Oct Thu, 16 Oct – Mon, 10 Nov

*GCE N(T)- & N(A) Level Examinations	Dates
Oral Examinations	Mon, 14 Jul (PM) Tue, 15 Jul - Thu, 17 Jul (Full-days) Fri, 18 Jul (PM)
Listening Comprehension	Tue, 16 Sep – Wed, 17 Sep
Practical & Written Examinations	Mon, 15 Sep – Thu, 25 Sep Mon, 6 Oct – Tue, 14 Oct

*GCE O-Level Examinations	Dates
Oral Examinations	Mon, 14 Jul (PM) Tue, 15 Jul - Thu, 17 Jul (Full-days) Fri, 18 Jul (PM)
	<u>MTB (Year-End)</u> Wed. 24 Sep (PM)

Submission deadlines for Coursework Subjects

Subject	Examination	Deadline
Art	GCE NT	13 May 2025 (Tuesday) 5.00 PM
	GCE NA	1 Aug 2025 (Friday) 5.00 PM
	GCE O	22 Sep 2025 (Monday) 5.00 PM
D&T	GCE NA / NT	18 Jul 2025 (Friday) 5.00 PM
	GCE O	31 Jul 2025 (Thursday) 5.00 PM

Multiple pathways for N(A) and N(T) students

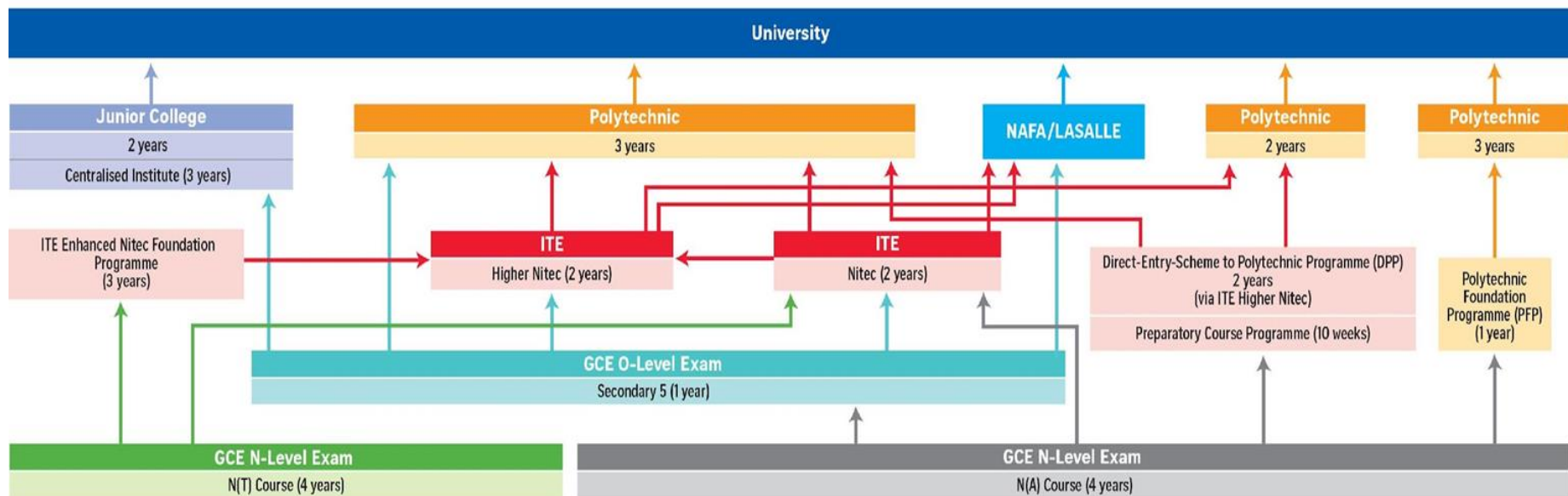

Source: MOE ST GRAPHICS ADAPTED FROM MOE



Graduate with a strong foundation for post-secondary & place of work!

Student Well-Being & Academic Matters

Year Head (Upper Secondary)
Mr Mohamed Ashiq

Student Well-being Check-in Survey

Administered to help HTs:

- Understand students' social-emotional needs, social support network and well-being as they enter the new school year
- Identify students for closer monitoring and support, including those who are having difficulties coping emotionally, facing family-related challenges, or struggling quietly and not reaching out for help.

Qn 1. How are you feeling about the new school year?

Feelings about starting the new school year

[students can choose more than 1 option]

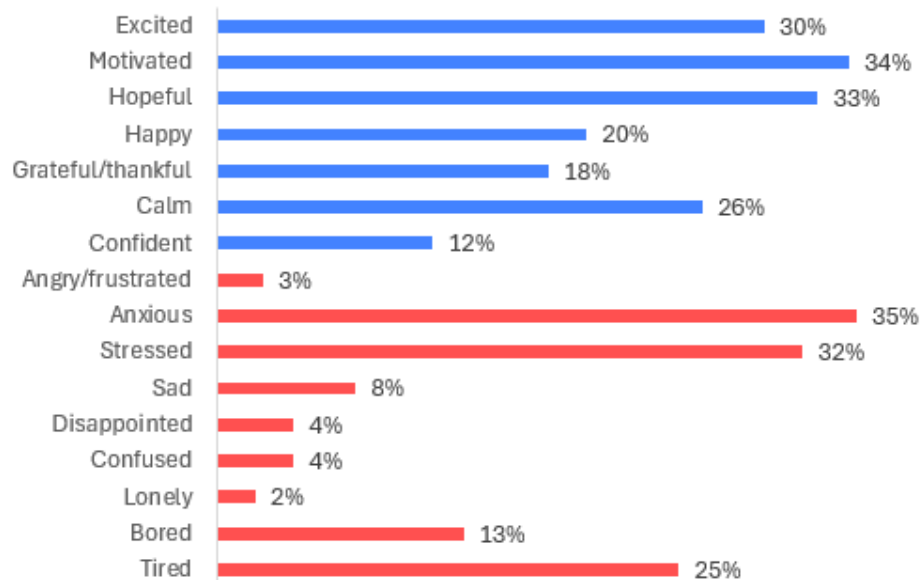

Qn 7. What are the things you worry about as you start the new school year?

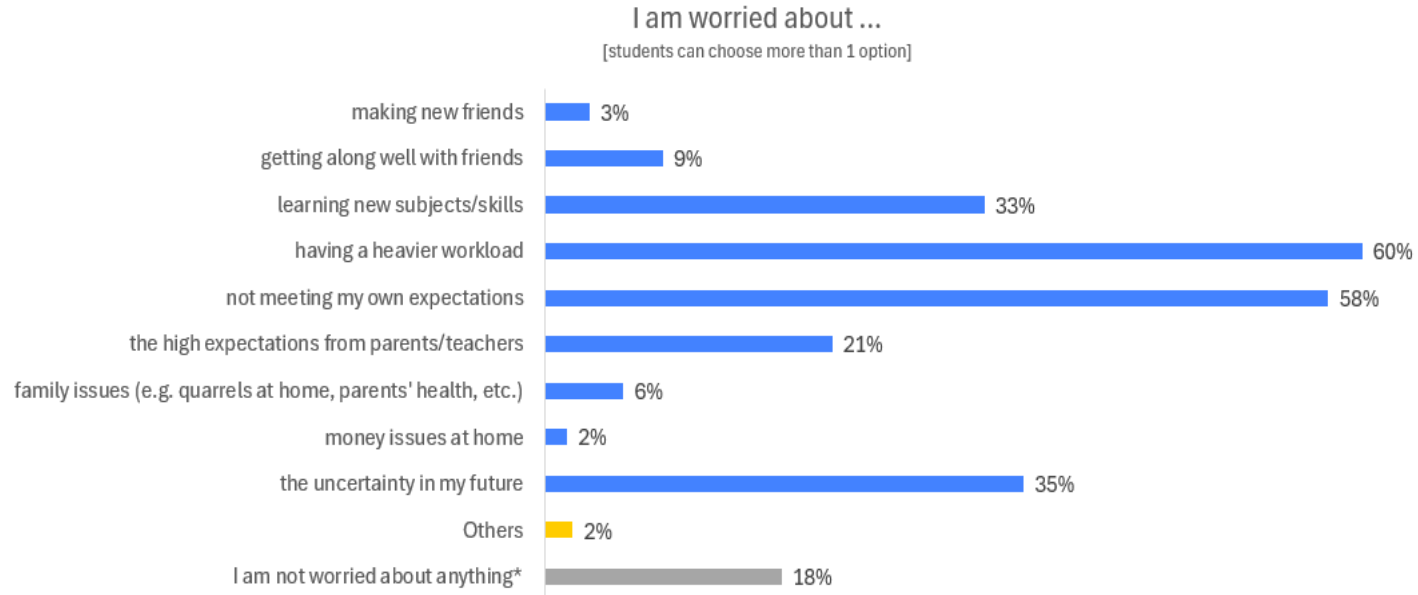

What Parents Can Do...

Overcoming stress by breaking down goals into small steps

- ☐ Achieving a big goal may seem overwhelming
- ☐ Break down broad goals into **smaller and realistic targets**.
 - ☐ Manage your expectations
- ☐ With each step, you are one step closer to your destination!

What Parents Can Do...

Need a listening ear?

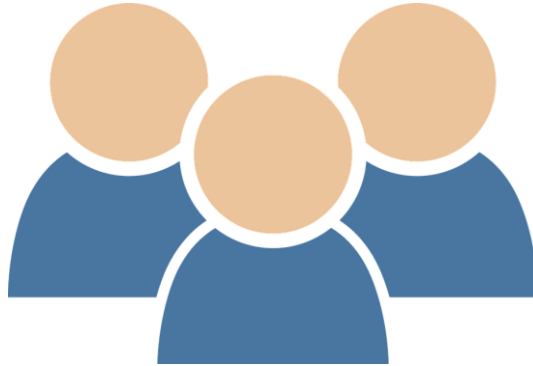

- Home Teachers and Year Head
- Friends
- School Counsellor
- Special Education Needs Officer

Parents can help to encourage your child to support their peers

Encourage them to:

- Check in on their friends from time to time.
- Be **inclusive**.
- Give their friends the reassurance.
- Show **empathy**, put themselves in their shoes.



Helplines for Support

Youth

- **Counselling for Youths** (13 -25 years old) Website: **eC2.sg**
- **CHAT** (16-30 years old) - **6493 6500/6501** (Tuesday to Saturday: 12pm – 9pm) or email: **CHAT@mentalhealth.sg**

General

- **SOS (Samaritans of Singapore) (24 hours) - 1800-221 4444**
- **IMH Emergency Hotline (24 hours) - 6389 2003 / 6389 2004**
- **National CARE Hotline (24 hours) – 1800 202 6868**

Academic Matters - Important Dates

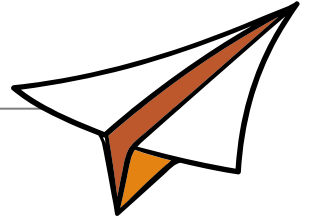

- Term 1 Weighted Assessment (WA1)
 - 10 – 28 February 2025
 - Conducted during class time
 - Max 2 subjects per day
 - Test dates & scope will be sent via PG
- Term 2 Weighted Assessment (WA2)
 - 28 April – 16 May 2025

Internal Examination Matters

Examination	Examination Period
4N Preliminary Examination	1 – 6, 12 – 15 Aug
4E5N Preliminary Examination	22 Aug – 3 Sep

Academic Support	Dates
Structured Revision & Targeted Intervention	17 & 18 Mar (During Mar holidays)
	3 – 5 June (During Jun holidays)
	8 & 9 Sep (During Sep holidays)
Post Preliminary Examination Revision Programme	[4N] 22 Aug – 3 Sep, 24 Sep – 3 Oct
	[4E5N] 15 – 25 Sep

National Examination Matters

Registration period for GCE O / NA / NT Level Examinations

- **27 February – 11 March 2025**

Application Deadline for Access Arrangements

- **End Feb 2025**
- Documents required from family: Doctor's report (medical / psychological)

CCA Matters(2025)

Clubs (2)

Audio Visual Lights
Tinkers' Club

Uniformed Groups (3)

NCC (Land)
NCDC
NPCC



Performing Arts (5)

Chinese Orchestra
Choir
Concert Band
English Drama
Modern Dance



Sports (6)

Badminton (Boys)
Basketball (B/G)
Floorball (Boys)
Football (Boys)
Netball (Girls)
Volleyball (B/G)



Performing Arts CCA



Singapore Youth Festival Arts Presentation 2025

(1st April to 7th May 2025)



CCA Stand down for Sec 4/5

2nd May 2025

*Exception for some Sports Groups participating at the National School Games and Performing Arts CCAs participating at the SYF Arts Presentation 2025.

Training/ CCA involvements will be kept minimal after 2nd May.



LEAPS 2.0 (Recognition for Co-curricular Attainment)

Domains

Leadership – Leadership development/positions.

Enrichment – Programmes students go through.

Achievement – School Representation, Achievements.

Participation – CCA Attendance and Involvement.

Service – Values in Action Projects, Service Hours.

Co-Curricular Experience	Basic Requirement for Level of Attainment in Domains	Bonus Points
Excellent	4,3,3,3	2
Good	4,1,1,1 3,2,1,1 2,2,2,1	1 (Minimum 1 for each domain & minimum 7 for total levels added up)
Fair	did not meet above criteria	0

LEAPS 2.0

Students will check their LEAPS 2.0 points at the end of May and will confirm their CCA Grades by September 2025.

For more info on LEAPS 2.0 Framework, please refer to this webpage



<https://www.moe.gov.sg/education-in-sg/our-programmes/cca/leaps2-0>

Education & Career Guidance Talk

MR DANIEL NG

SUBJECT HEAD

CHARACTER & CITIZENSHIP EDUCATION



Education & Career Guidance in PRSS

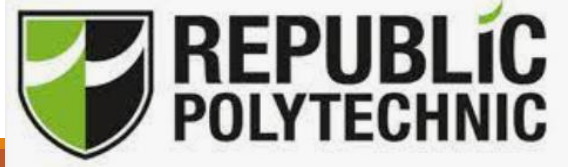

Broad ECG Approach

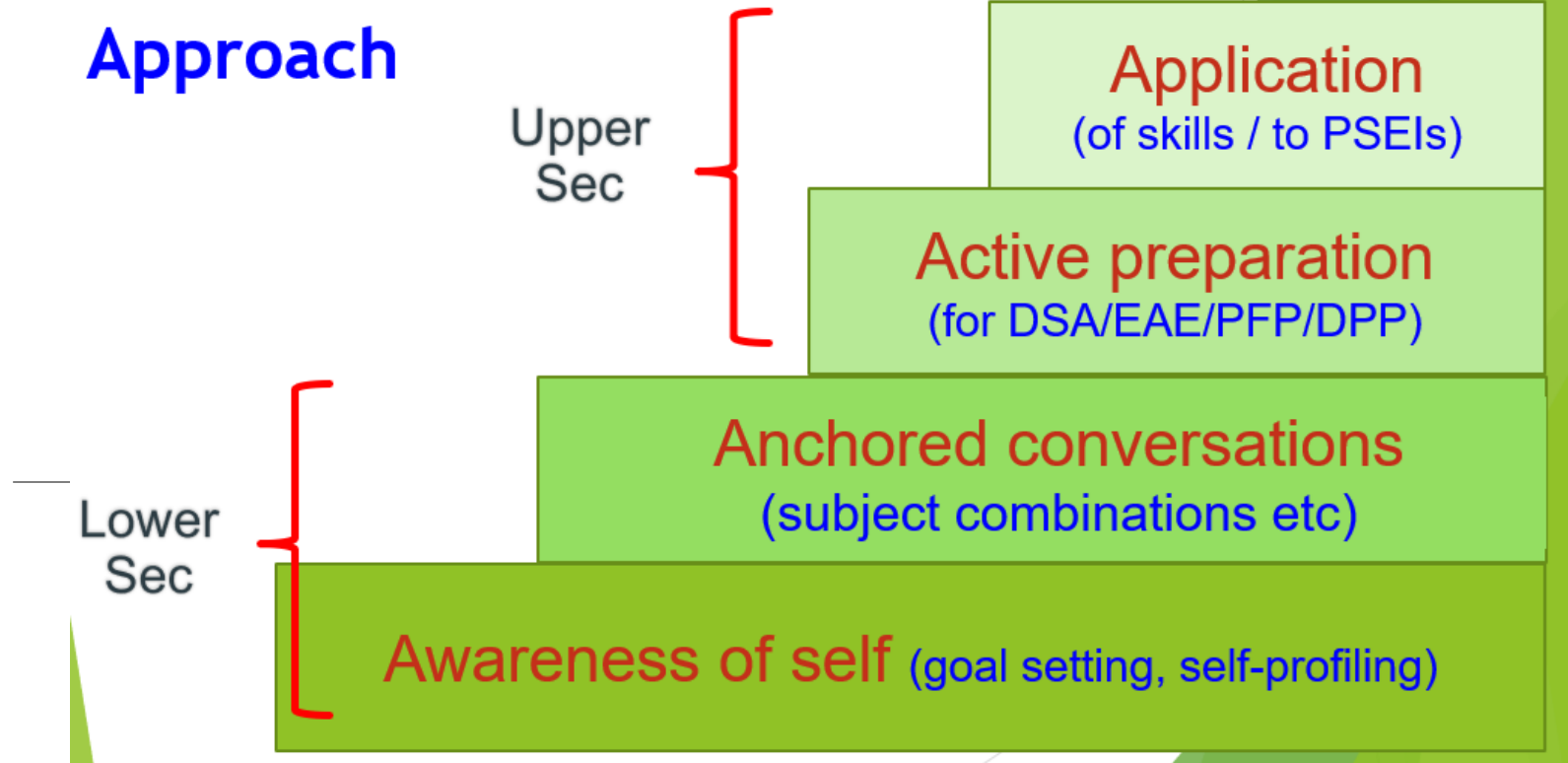

Through ECG curriculum, the school aim to inspire students to:

- **Appreciate** all occupations
- **Discover** talents and interest
- **Acquire** Knowledge, Skills and Values to make informed decisions on post-sec education
- **Pave** their own education and career pathways
- **Tap** on stakeholders for support and guidance

Key messages to students:

-
1. Discover Who You Are
 2. Navigate Pathways with Confidence
 3. Make Informed Decisions and Take Ownership of Your Own Educational Pathway

Term 1 activities (S4/5):

- Young Alumni Sharing (Camp Conquest)
- Poly visits during Camp Quest/Conquest
 - Students visited 2 of the following pairs of school based on their choice during TP Open House:
 - School of Design & School of Business
 - School of Applied Science & School of Engineering
 - School of Humanities & School of Design
- DSA/JC/EAE talks by ECGC
- ECG Consultation by ECGC

Term 2 activities (S4/5):

- Career & Industry Fair

Class briefing by ECGC



Young Alumni Sharing (Camp Conquest)



- ECG talks by ECG Counsellor (ECGC)
- EAE / DSA / DPP / PFP workshops by ECGC
- Individual & group counselling / coaching by ECGC by appointment
- Learning Journeys e.g. Poly visits
- Applied Learning Modules at ITE/Poly (S3 – selected classes)
- Career Awareness Day / STEAM Festival
- ECG programmes in Level Camps



TP Open House (Camp Conquest)



Post-Secondary Admissions Exercises for O-Level Students

Where am I now?

What admissions exercises can I take part in?

Where do I want to go?

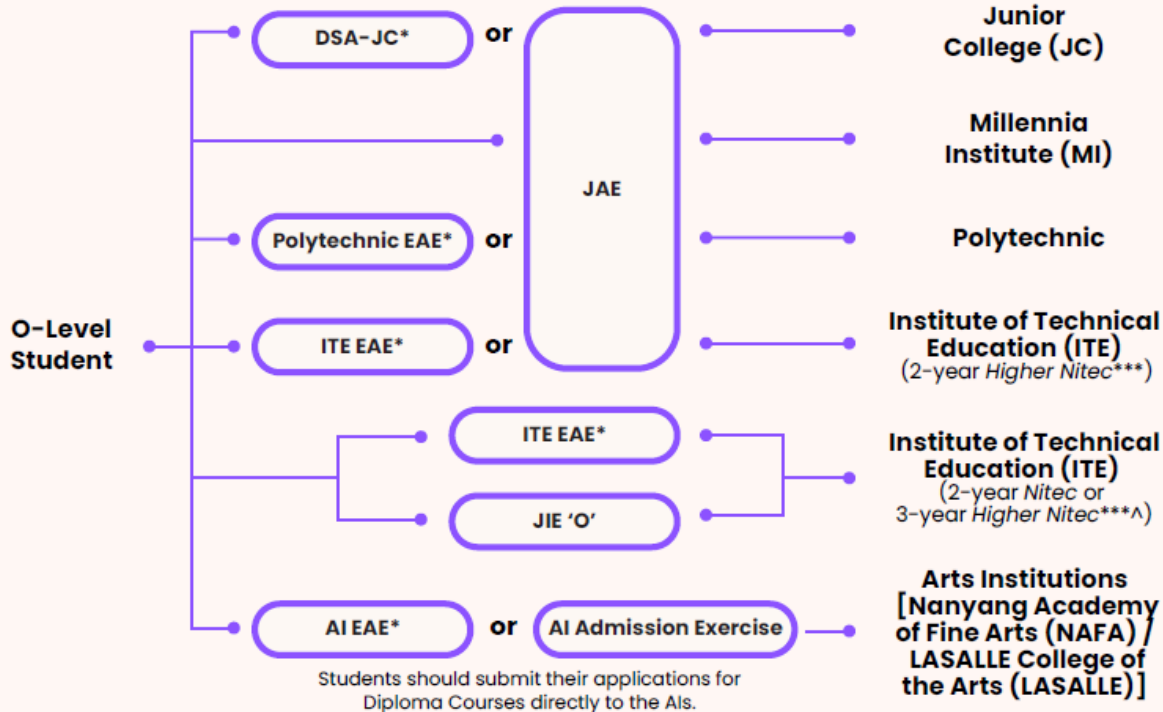

When can I start to apply?

May

- DSA-JC*
- ITE EAE*
- AI EAE* (LASALLE)

Jun

- Polytechnic EAE*
- AI EAE* (NAFA)

(O-Level Exams)

Oct/Nov

- LASALLE**
- NAFA**

(O-Level Results)

Jan

- JAE
- JIE 'O'

O-Level Student

*Students apply through these admissions exercises before their O-Level examinations.

**Application to LASALLE's and NAFA's diploma programmes starts from October.

***Selected Nitec and Higher Nitec courses are available in traineeship mode.

^For the list of 3-year Higher Nitec courses, please visit [here](#).

For more information on applying to these courses, you can visit [here](#).

N(A)-Level Student

Eligible students may also progress to Secondary 5 to take the O-Level examinations. Applications can be made via your secondary school.

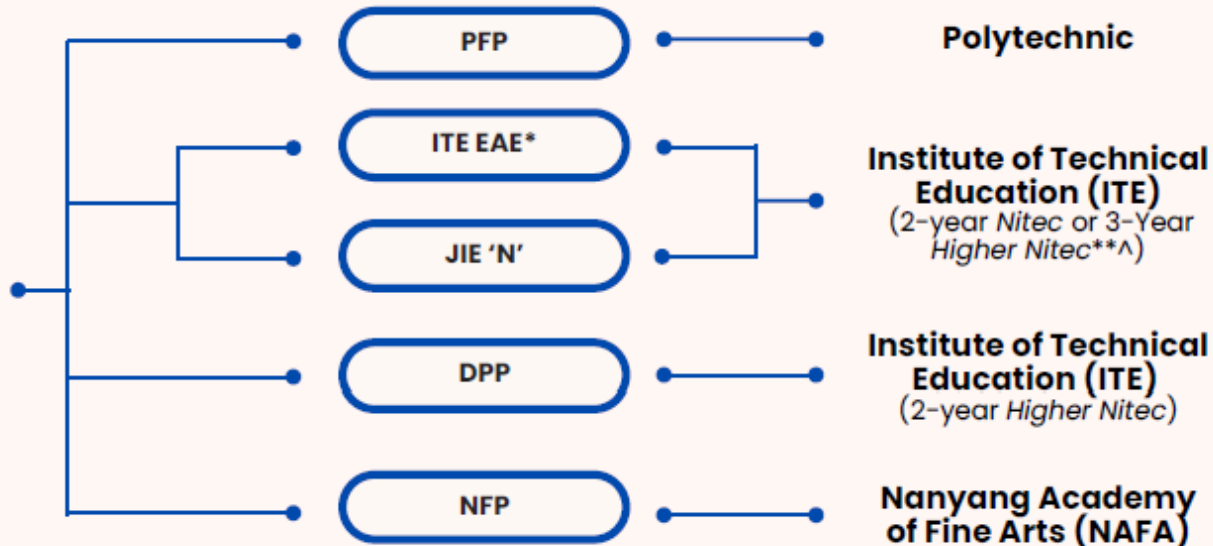

When can I start to apply?

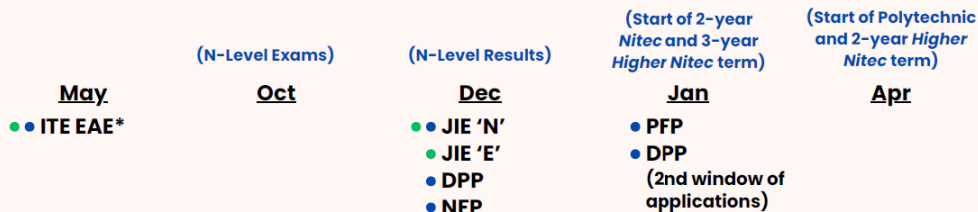

*Students can apply through these admissions exercises before their examinations.

**Selected Nitec and Higher Nitec courses are available in traineeship mode.

^For the list of 3-year Higher Nitec courses, please visit [here](#).

For more information on applying to these courses, you can visit [here](#).

N(T)-Level Student

Eligible students may also laterally transfer to Secondary 4 N(A) to take the N(A)-Level examinations. Applications can be made via your secondary school.

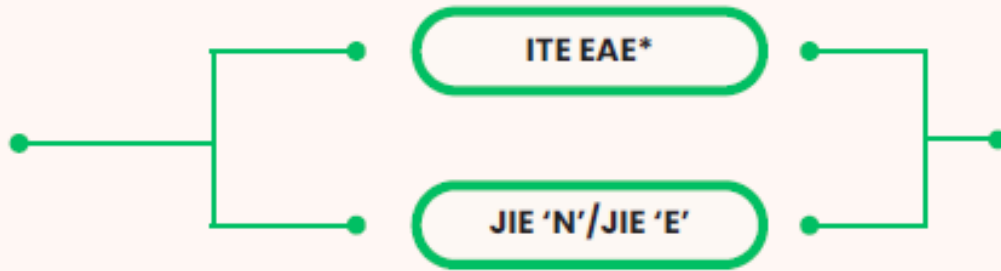

Institute of Technical Education (ITE)
(Enhanced Foundation Programme, 2-year *Nitec* or 3-year *Higher Nitec***^)

When can I start to apply?

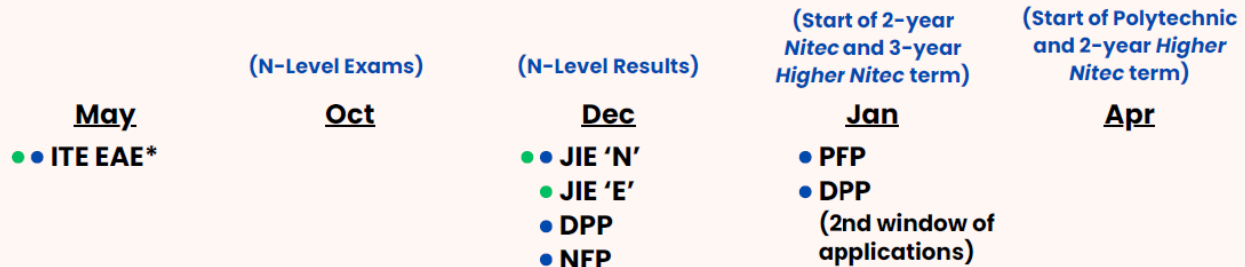

 N(T)-Level Student

 N(A)-Level Student

*Students can apply through these admissions exercises before their examinations.

**Selected *Nitec* and *Higher Nitec* courses are available in traineeship mode.

^For the list of 3-year *Higher Nitec* courses, please visit [here](#).

For more information on applying to these courses, you can visit [here](#).

ECG Conversations with your child

The 3 ECG Questions

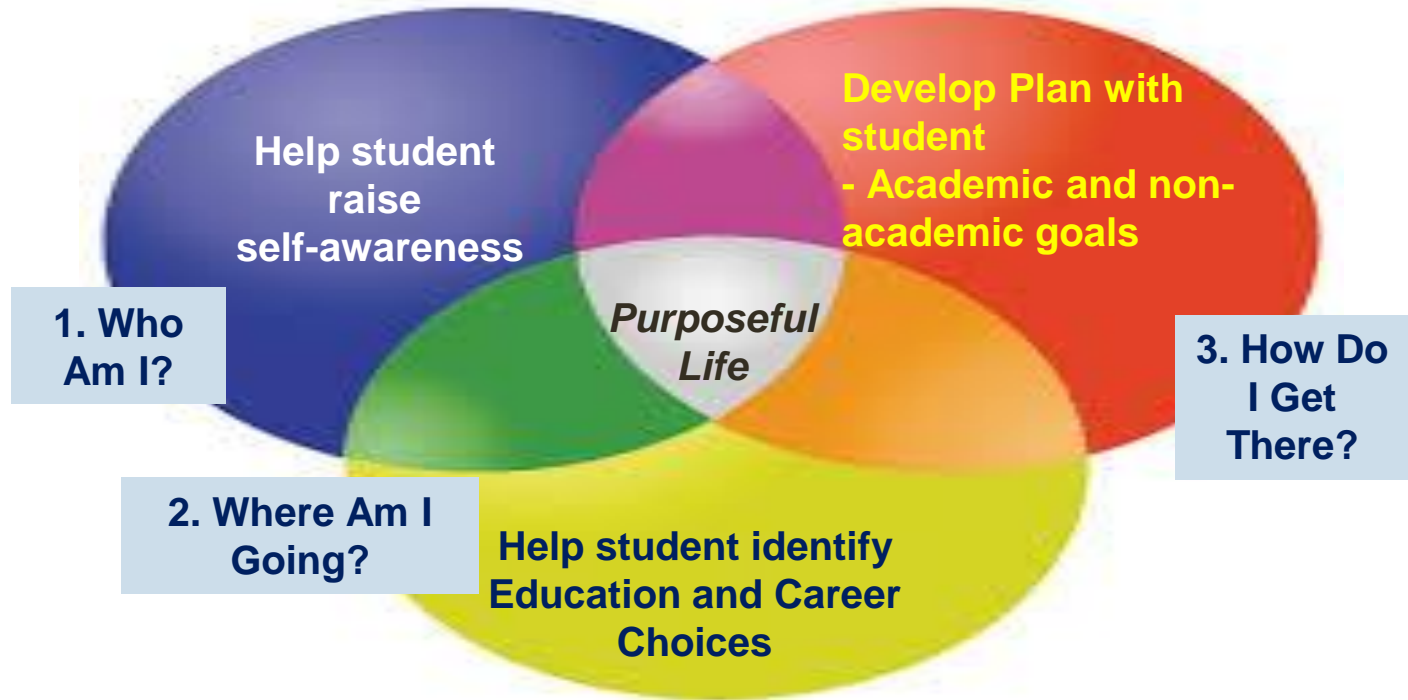

Booking of ECG Counselling Session with Mr Syahril

Scan the QR Code below



Link:

<https://go.gov.sg/ecgbookingprss>

Email:

mohammed_syahril_samsudin@schools.gov.sg

<https://go.gov.sg/ecgbookingprss>

Thank you!

